

**Prestressed Lintels**

		Working Load Capacity (kN/m)											
		Ope Width / Span (m)	1	1.2	1.4	1.5	1.8	2	2.5	3	3.3	3.6	4
	<b>4" x 3"</b>	<b>DEPTH OF COMPOSITE LINTEL</b>											
		65mm (No Blocks)	2.60	1.89	1.43	1.26	0.86	0.71	0.47	0.34	X	X	X
		290mm (1 Course, + 225)	8.93	6.48	4.91	4.34	2.95	2.44	1.62	1.15	X	X	X
		390mm (To Ceiling, + 325)	17.20	12.48	9.47	8.36	5.69	4.70	3.12	2.22	X	X	X
		515mm (2 Course, + 450)	31.34	22.74	17.25	15.22	10.36	8.56	5.69	4.05	X	X	X
	<b>6" x 3"</b>	<b>DEPTH OF COMPOSITE LINTEL</b>											
		65mm (No Blocks)	2.99	2.17	1.64	1.45	0.99	0.82	0.54	0.39	X	X	X
		290mm (1 Course, + 225)	13.39	9.72	7.37	6.50	4.43	3.66	2.43	1.73	X	X	X
		390mm (To Ceiling, + 325)	25.81	18.73	14.21	12.54	8.53	7.05	4.68	3.33	X	X	X
		515mm (2 Course, + 450)	47.01	34.11	25.88	22.84	15.54	12.84	8.53	6.07	X	X	X
	<b>9" x 3"</b>	<b>DEPTH OF COMPOSITE LINTEL</b>											
		65mm (No Blocks)	5.32	3.86	2.93	2.59	1.76	1.45	0.97	0.69	X	X	X
		290mm (1 Course, + 225)	19.19	13.93	10.56	9.32	6.34	5.24	3.48	2.48	X	X	X
		390mm (To Ceiling, + 325)	36.99	26.84	20.36	17.97	12.23	10.11	6.71	4.78	X	X	X
		515mm (2 Course, + 450)	67.38	48.89	37.09	32.73	22.28	18.41	12.22	8.70	X	X	X
	<b>4" x 6"</b>	<b>DEPTH OF COMPOSITE LINTEL</b>											
		150mm (No Blocks)	16.80	12.19	9.25	8.16	5.55	4.59	3.05	2.17	1.81	1.54	1.26
		375mm (1 Course, + 225) 5N Blocks	13.22	9.59	7.28	6.42	4.37	3.61	2.40	1.71	1.43	1.21	0.99
		600mm (2 Course, + 450) 5N Blocks	39.02	28.32	21.48	18.96	12.90	10.66	7.08	5.04	4.21	3.57	2.93
		375mm (1 Course, + 225) 15N Blocks	39.67	28.78	21.83	19.27	13.11	10.84	7.20	5.12	4.28	3.63	2.97
		600mm (2 Course, + 450) 15N Blocks	117.06	84.95	64.44	56.87	38.70	31.99	21.24	15.12	12.64	10.72	8.78

**Recommended Fitting Procedure for Greaney Pre-stressed Concrete Lintels**

For a 4" x 6" (100mm x 150mm) lintel always turn the rough side down. Lintel has higher load capacity in the position i.e. two wires at bottom.

July 2015

**Recommended procedure for positioning Greaney Concrete Lintel**

- Handle with care.
- Place lintel over ope with >150mm bearing length (B) on each wall for opes up to 1.5m width. B > 200mm on ope width from 1.5m to 3m.
- If positioned "smooth side up" coat with scud i.e. cement/water mix and allow to cure. As stated above always place a 4" x 6" lintel with rough side down.
- Always prop bare lintel before placing masonry blocks overhead.

**Introduction**

Concrete lintels are the most common way of supporting masonry over opes. On their own they support very little and are always used together with overhead masonry in what is called a "composite lintel". Height, quality and strength of relevant masonry overhead dictates load bearing capacity of the composite lintel.

Prestressed lintel provides the "tension" element of the composite beam with multiple strands of high grade steel wire within. Prestressed wire has surrounding concrete in compression allowing it to expand under load without cracking. Pre-stressing also ensures lintel stays intact during transport and positioning.

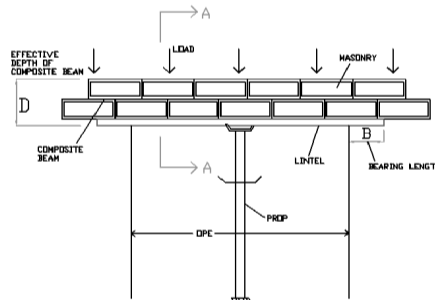

Figure 1.

Common concern is "which way to turn the lintel" i.e. rough side up or rough side down. The correct way is rough side up so the lintel can properly fuse with overhead masonry reducing the likelihood of tension cracks appearing on masonry immediately over lintel.

When analysing the load capacity of composite lintels, orientation of the lintel is not a factor as worst case situation would be appearance of hairline tension cracks on the block work immediately overhead the lintel. This is a cosmetic issue and not a structural one. In practice this never happens.

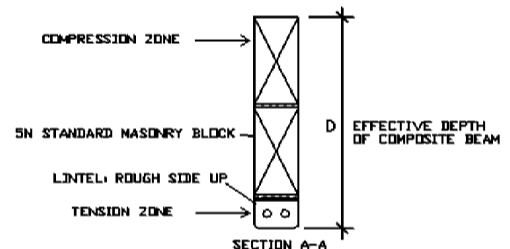

Figure 2.

- Use good mortar 1:6 cement:sand ratio and good quality blocks. Regular block work assumed at 5N/mm<sup>2</sup>.
- Refer to load table to ensure composite lintel is adequate for imposed load.
- Allow masonry to cure before removing prop.

**Precast Lintels**

- Always place with rough side up.

**Precast Lintels**

	<b>4" x 9"</b>	<b>Ope Width / Span (m)</b>	1	1.2	1.4	1.5	1.8	2	2.5	3	3.3	3.6	4	4.5	
		Working Load Capacity (kN/m)	27.0	19.6	14.9	22.3	15.9	13.0	10.2	6.3	7.5	5.9	4.4	X	
		Top Reinforcement	T12	T12	T12	T12	T12	T12	T12	T12	T12	T16	T16	T16	X
		Bottom Reinforcement	T12	T12	T12	T16	T16	T16	T20	T20	T25	T25	T25	T25	X
	<b>6" x 9"</b>	<b>Ope Width / Span (m)</b>	1	1.2	1.4	1.5	1.8	2	2.5	3	3.3	3.6	4	4.5	
		Working Load Capacity (kN/m)	54.4	39.7	30.1	43.1	30.8	25.3	21.4	13.0	10.3	11.5	8.6	6.5	
		Top Reinforcement	T12	T12	T12	T12	T12	T12	T12	T12	T12	T12	T16	T16	T16
		Bottom Reinforcement	T12	T12	T12	T16	T16	T16	T20	T20	T20	T25	T25	T25	T25
	<b>9" x 9"</b>	<b>Ope Width / Span (m)</b>	1	1.2	1.4	1.5	1.8	2	2.5	3	3.3	3.6	4	4.5	
		Working Load Capacity (kN/m)	55.7	40.5	30.6	45.4	32.3	26.4	21.3	13.0	10.0	12.0	7.3	5.0	
		Top Reinforcement	T12	T12	T12	T12	T12	T12	T12	T12	T12	T12	T16	T16	T16
		Bottom Reinforcement	T12	T12	T12	T16	T16	T16	T20	T20	T20	T25	T25	T25	T25

**Note: Deflection of all precast lintels limited to L/250**  
For specific design requirements, please contact Greaneys directly. Precast Lintels are made to order.