



DECLARATION OF PERFORMANCE

DOP Ref: QL-B7-150

1. Unique Identification code of Product type
140mm Quinn Lite Standard (B7) (GPLM)
2. Type, Batch or Serial Number or any other Element allowing identification of the Product
See Point 1
3. Intended use or uses of the product, in accordance with the applicable harmonised technical specification

For use in the construction of load bearing and non-loadbearing solid internal and external walls, above and below the damp proof course and the inner and outer leaves of cavity walls
4. Name and registered address of manufacturer
Quinn Building Products, 235 Ballyconnell Road, Derrylin, Co. Fermanagh, Northern Ireland, BT92 9GP
5. Where applicable, name and contact address of the authorised representative whose mandate covers tasks specified in Article 12(2):
Not Applicable
6. System or systems of assessment and verification of constancy of performance of the construction product as set out in CPR, Annex V:
System 2+
7. In case of the declaration of performance concerning a construction product covered by a harmonised standard:
The notified product certification body, British Standards Institution (Notified Body reference no. 0086) has performed the initial inspection of the manufacturing plant and of factory production control, the continuous surveillance, assessment and evaluation of factory production control before placing the product on the market under system 2+ and issued the certificate of constancy of performance.
8. Declared Performance
Refer to table attached
9. The performance of the product identified in points 1 and 2 is in conformity with the declared performance in point 8. The declaration of performance is issued under the sole responsibility of the manufacturer identified in point 4.

DECLARATION OF PERFORMANCE

Quinn Building Products 235 Ballyconnell Road, Derrylin, Co. Fermanagh, Northern Ireland, BT92 9GP		
EN 771-4:2011+A1:2015 Specification for masonry units – Part 4: Autoclaved Aerated Concrete Masonry Units		
13 0086-CPR-597549		
Essential Characteristics	Performance	Harmonised Technical Specification
Dimensions <i>mm</i>	Length	440
	Width	150
	Height	215
Configuration		Solid Group 1
Dimensional Tolerances		GPLM
Compressive Strength unit category		I
Mean Compressive Strength N/mm^2		7.5
Dimensional Stability (Shrinkage) mm/m		0.4
Shear Bond Strength N/mm^2		0.15 (Annex C BS EN 998-2)
Flexural Bond Strength N/mm^2		NPD
Reaction to Fire		Euroclass A1
Water Absorption $g/m^2s^{0.5}$		NPD
Water Vapour Diffusion coefficient μ		5/10 (Tabulated values BS EN 1745)
Durability against freeze thaw		NPD
Gross Dry Density Kg/m^3		760
Thermal Conductivity $W/m.k$		0.17 ($\lambda_{10,dry}$)
Dangerous Substances		See footnote
Note: Information on dangerous substances will only be given when and where required in the appropriate form. See Annex ZA.3 of BS EN 771-4:2011		

Configuration on Edge

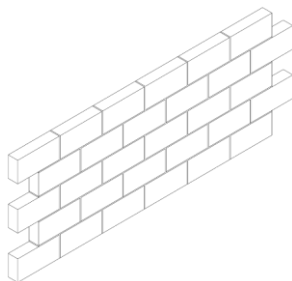

Configuration on Flat

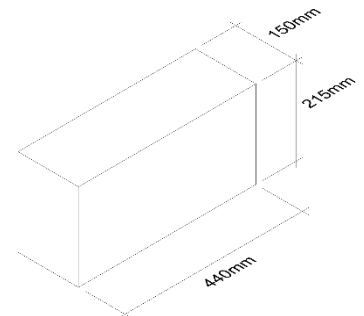
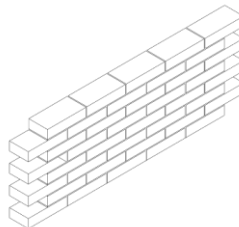

Authorised by: Liam McCaffrey
 Position: CEO
 Date of Issue: 23rd May 2016